

TECHNICAL SPECIFICATION Rockwheel C1 Tiller

Hydraulic Power	9,5 kW
Maximum Oil flow	60,0 l/min
Optimum Oil flow	30,0 l/min
Maximum Pressure	200 bar
Operating Weight	80 kg
Width brush	650 mm
Excavator size	0,7 – 3,5 t
Speed	150 rpm @ 30l/min

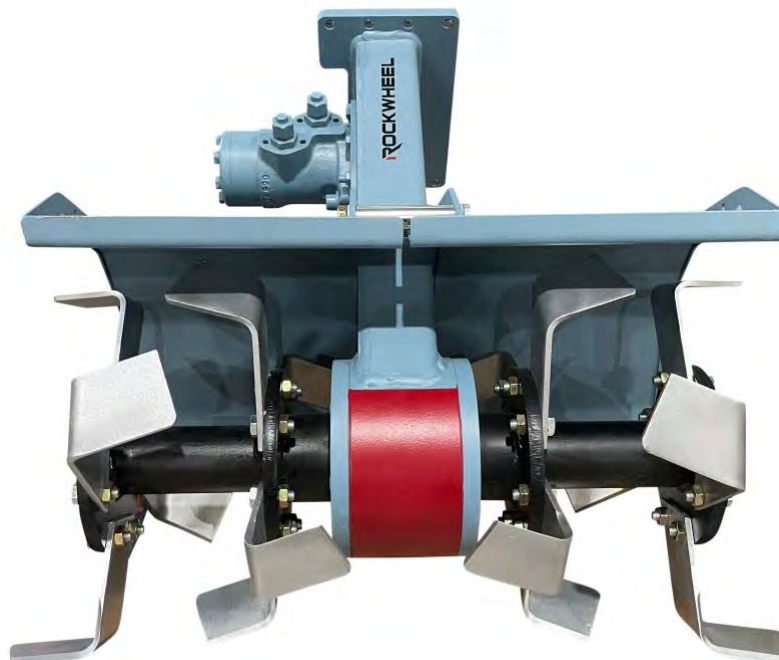

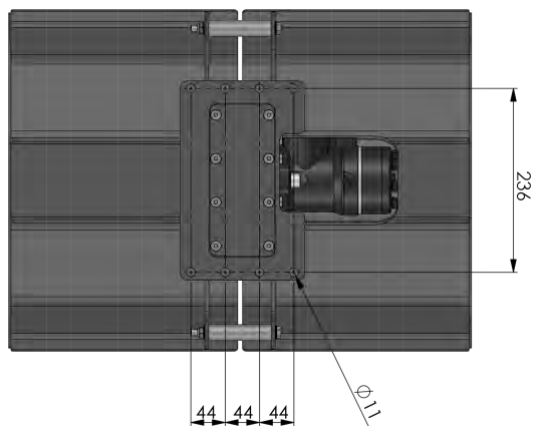
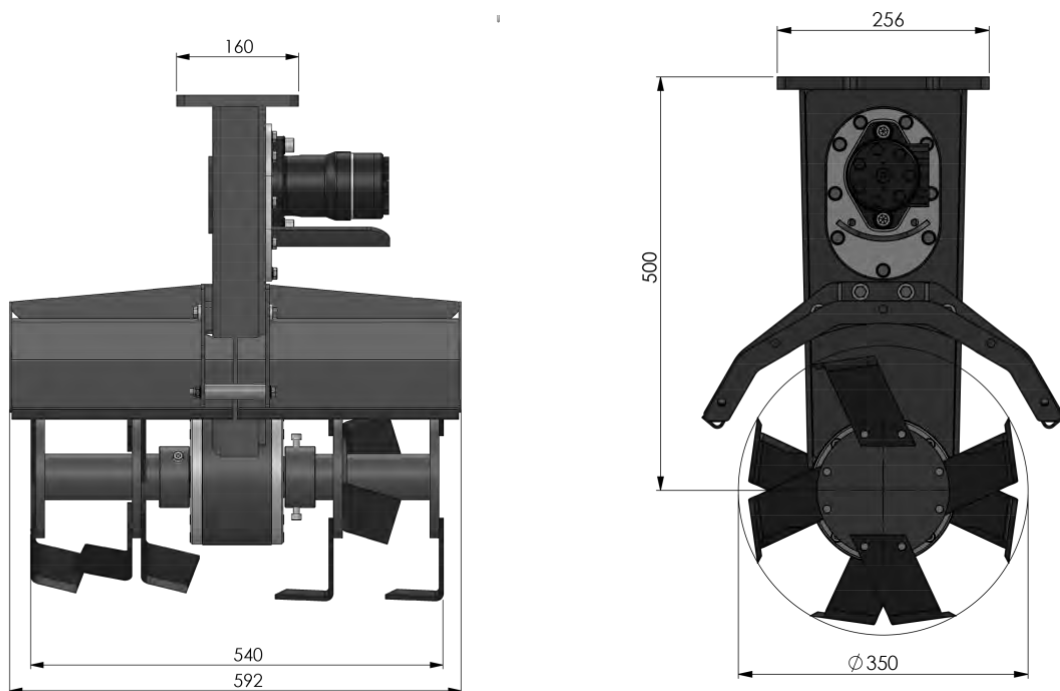

Also available with brush:

